

H = 1.0±0.1mm (Height)  
 L = 2.3±0.1mm (Length)  
 W = 2.0±0.1mm (Width)  
 LW = 10±1mm (Lead length)  
 Lφ = 0.2±0.02mm (Lead diameter)

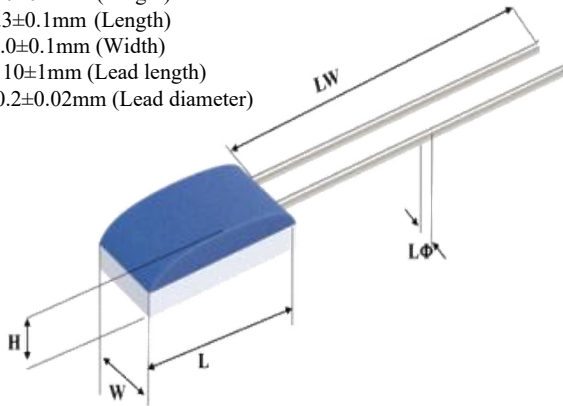

**MAIN FEATURES**

- **PT20 series thin film platinum resistors have the advantages of small size, high precision and good long-term stability.**
- **It has the characteristics of anti-vibration and anti-shock.**
- **The product can be subdivided into regular ultra low and high temperature series, covering the temperature range of -70 to 500°C.**
- **It can be used in many connection ways, such as resistance welding, argon arc welding, pressure welding, brazing and so on.**
- **Widely used in automotive, instrumentation, household appliances, new energy and other fields.**

\*The nominal resistance measurement point is 8mm away from the component body



**TECHNICAL INDEX**

Performance parameters	Thin film platinum resistance series	Component size	2.0mmx2.3mmx1.0mm
Lead specifications	Length:10mm; Diameter:0.2mm	Lead material	Platinum nickel; Silver target; Pure Platinum; Sterling silver;
Lead tension	≥9N	Insulation impedance	>100MΩ at 20°C、 > 2MΩ at 500°C
Temperature coefficient (TCR)	3850ppm/°C	Working current	0.3- 2mA (Self-heating should be considered)
Long-term stability	After 1000 hours at 500°C , the resistance shift of R(0°C) is less than0.04%		
Response time	Water flow(v=0.4m/s) τ <sub>0.5</sub> =0.1s τ <sub>0.9</sub> =0.3s	Airflow(v=2m/s)	τ <sub>0.5</sub> =5s τ <sub>0.9</sub> =15s
Natural coefficient	0°C 0.4°C/mW	Anti-vibration	Frequency acceleration ≥40g from 10 to 2000Hz
Impact resistant	8ms half sine wave acceleration ≥100g	Package	Vacuum plastic packaging (Provide other packaging forms as required)
Others	Substrate size, basic resistance value, lead specifications (can be provided upon request)		



**REFERENCE SELECTION**

Type	Range of application	Classes	R <sub>0</sub> (Ω)	Temperature range	Accuracy
Pt20-2W	-70~+500°C	A	20±0.012	-50~+300°C	±(0.15+0.002 T )
		B	20±0.024	-70~+500°C	±(0.3+0.005 T )
		2B	20±0.048	-70~+500°C	±(0.6+0.01 T )

Note \* : the marked classes and temperature measurement accuracy refer to the IEC60751 standard. T is the measured temperature.